

CRIZTO SINGAPORE PTE LTD

10 Tampines North Drive 4 #04-08/09/10/11
 JTC Space @ Tampines North Singapore 528553
 T: +65 6287 5287 | F: +65 6287 9287 | E: sales@crizto.com
 W: www.crizto.com | www.facebook.com/CriztoSingapore

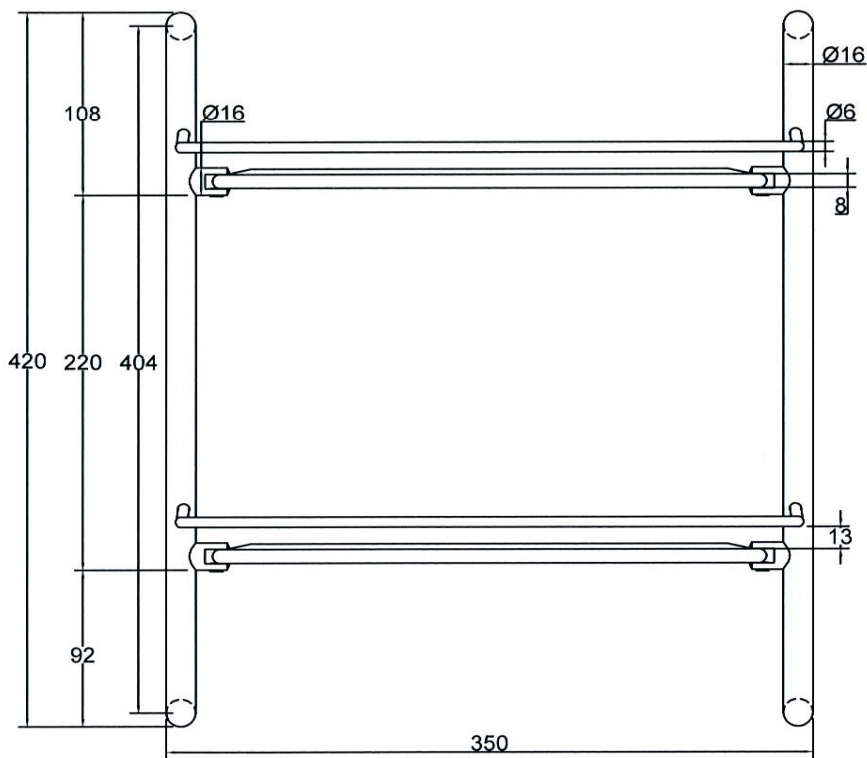

SANITARY WARE SPECIFICATIONS & TECHNICAL DRAWINGS

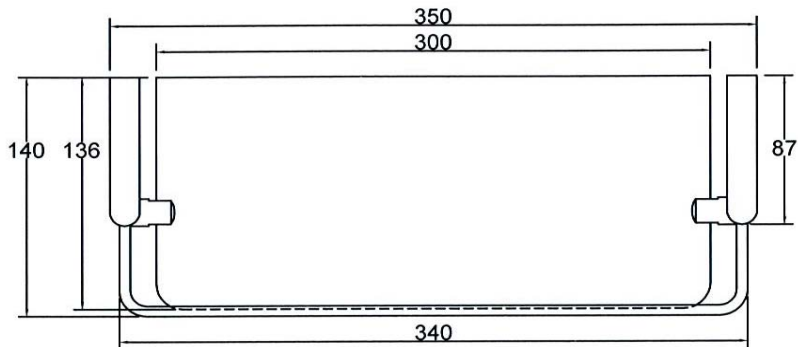

MODEL NO. CM-102-12-2		SERIES GLASS SHELF
DESCRIPTION CRIZTO DOUBLE LAYER GLASS SHELF		
DIMENSION L350MM X W140MM X H420MM		
SCALE 1.8KG	DATE 01-12-2016	DRAWING NO. CM-102-12-2-01