

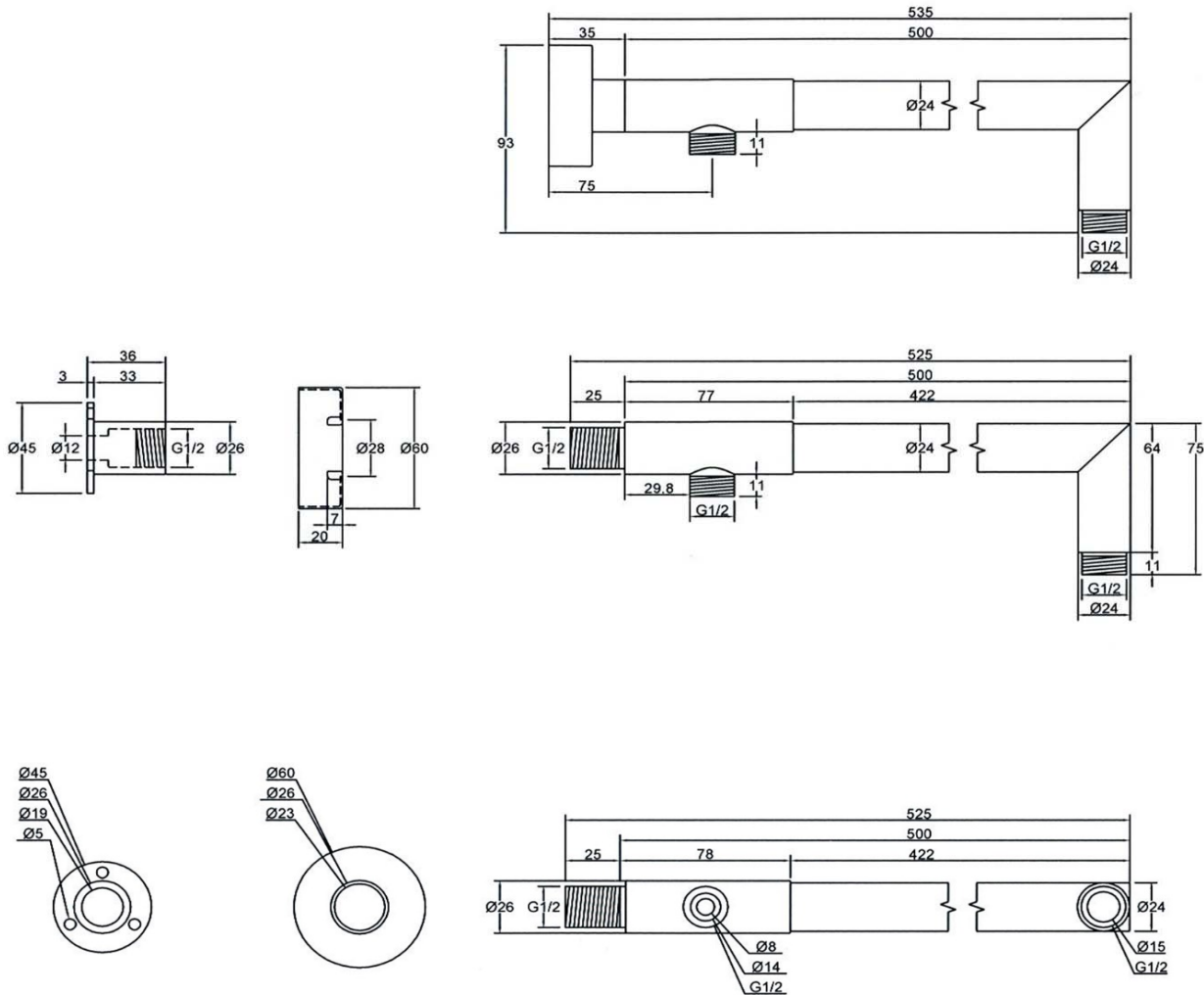

**SANITARY WARE SPECIFICATIONS & TECHNICAL DRAWINGS**



	MODEL NO. <b>CRS-ESA03-C</b>		SERIES <b>SHOWER ARM</b>
	DESCRIPTION CRIZTO ROUND SHOWER ARM		
	DIMENSION L500MM X D24MM		
	SCALE	DATE 01-12-2016	DRAWING NO. CRS-ESA03-C-01